

## ROZMERY

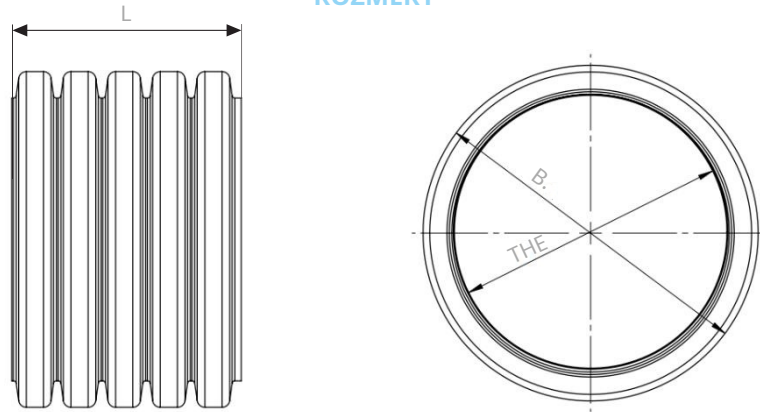

	A [mm]	Š [mm]	D [m]	Minimálny polomer ohybu [mm]
SRD-C-200 63	52	63,2	50	150
SRD-C-200 75	62	76,2	50	170
SRD-C-200 90	75	90,6	50	250

## DIAGRAM STRÁT TLAKOV

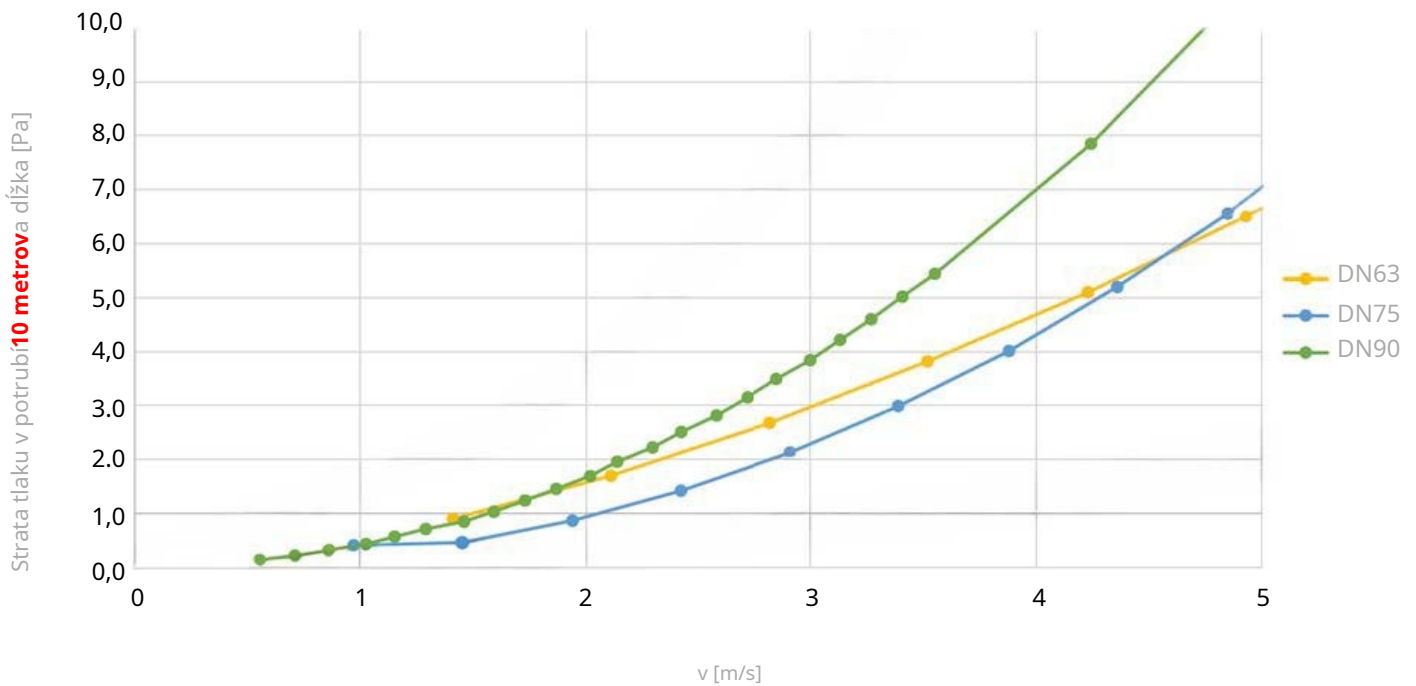

## DOPRAVA [m<sup>3</sup>/h]

DN [mm]	Rýchlosť vzduchu [m/s]						
	0,5	1,0	1,5	2,0	3,0	4,0	5,0
63	3,9	7,8	11,7	15,6	23,4	31,2	39,0
75	5,3	10,5	15,8	21,0	31,6	42,1	52,6
90	7,8	15,7	23,5	31,4	47,1	62,8	78,5

